



# STAIRWELL OPENINGS PARALLEL TO I-JOIST FLOOR FRAMING

When framing a residential floor with I-joists, the builder often must allow for an unsupported stairwell opening where the joists run parallel to the opening. This *Builder Tip* simplifies the selection of trimmers and headers, provides guidance on appropriate detailing for their use, and quantifies hanger capacity requirements for I-joist-to-header and header-to-trimmer intersections.

The most common method for placing a stairwell in a wood-framed floor is to run the long axis of the opening parallel to the span of the I-joist. This generally requires smaller headers and trimmers than when oriented perpendicular to the joist span.

These recommendations are based on the use of APA I-joists in either single or multiple allowable spans for residential applications per APA Performance Standard PRI-400, and on a **total load of 50 psf** for the floor and stair area. It is also assumed that there is a non-load-bearing partition load of 64 plf along one header and trimmer.

This information is appropriate for stairwell openings from **10.5 ft to 12 ft in length and 48 inches in width**, whose long dimension is running parallel to the joist span, as shown in Figure 1. When these recommendations are followed, it is unnecessary to support the stairwell opening from below with vertical framing members.

### Limitations

The stair stringers may be attached to the header/trimmer at either end of the stairwell opening. The stairwell opening may be placed anywhere in the floor as long as the provisions of this *Builder Tip* are met.

### Stairwell Design and Detailing

Use Table 1 to determine the minimum capacity I-joist requirement or the capacity of other engineered wood members required to frame the headers and trimmers shown in Figure 1.

*Caution:* In situations where the floor joists connected to the stairwell header are installed over two or more spans, these continuous floor joists should be cut at the center support as shown in Figure 1. The builder must then insure that the maximum allowable simple span is not exceeded after these I-joists are cut.

The strength and stiffness requirements for headers and trimmers are shown in Table 1. The header and trimmer requirements can be satisfied by the use of single or multiple I-joists, or engineered wood

FIGURE 1

### STAIRWELL OPENINGS IN APA I-JOIST FLOORS

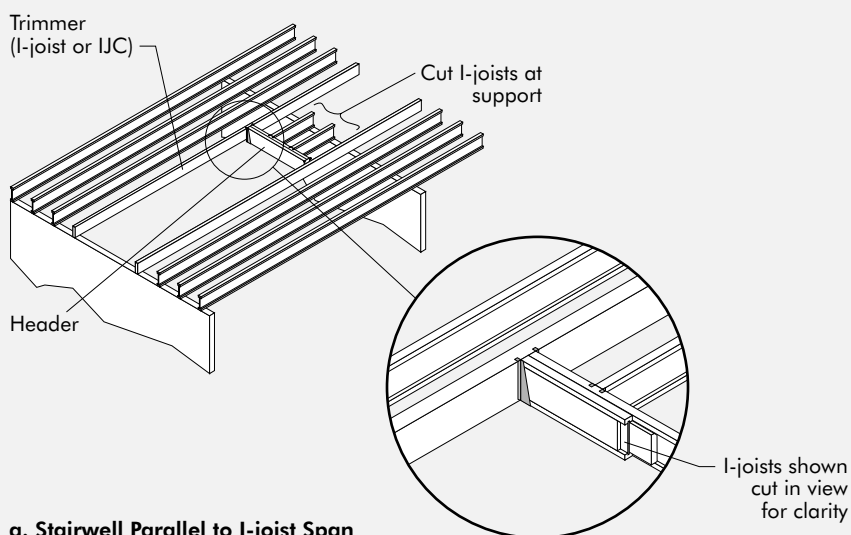

a. Stairwell Parallel to I-joist Span

### TERMS

- Header:** Framing member that supports the cut ends of I-joists
- Trimmer:** Framing member that supports the header

headers or trimmers in I-joist compatible depths (IJC). Glued laminated timber (glulam) beams or laminated veneer lumber (LVL) beams are recommended.

**Headers:** The stairwell header may be made up of the single I-joist as specified in Table 1, but some designers may prefer to use a double I-joist for framing. Also provided are minimum IJC engineered wood products that may be used in lieu of an I-joist.

Install backer blocks behind any face- or top-mounted hangers attached to an I-joist or double I-joist header.

The headers are attached to the trimmers with metal hangers, as shown in Figure 1. Select hangers that are sized to fit the dimensions of the single I-joist, double I-joist, or engineered wood headers and that have a minimum capacity of 1,450 lbf for all applications in Table 1. As shown in Table 1, under "Joist to Header Hanger Requirement," hangers of the same 1,450 lbf capacity may also be used where the floor I-joists intersect the header.

**Trimmers:** Table 1 also gives the minimum alternative IJC engineered wood products to be used for the required trimmer capacities.

TABLE 1

**REQUIRED HEADERS AND TRIMMERS FOR STAIRWELL OPENINGS PARALLEL TO APA I-JOIST FLOOR**

| Max. I-joist Clear Span (ft) | Header Requirements   |                  |                  |                                      |
|------------------------------|-----------------------|------------------|------------------|--------------------------------------|
|                              | Suggested I-Joist     | Alternative IJC  |                  | Joist to Header Hanger Requirement   |
|                              |                       | LVL              | Glulam Beam      |                                      |
| 14                           | (1 ea.) 9-1/2 PRI-20  |                  |                  | Type A                               |
| 16                           | (1 ea.) 9-1/2 PRI-40  | 1-3/4" x 9-1/2"  | 3-1/2" x 9-1/2"  |                                      |
| 18                           |                       |                  |                  |                                      |
| 20                           | (1 ea.) 11-7/8 PRI-40 | 1-3/4" x 11-7/8" | 3-1/2" x 11-7/8" |                                      |
| 22                           |                       |                  |                  |                                      |
| Max. I-joist Clear Span (ft) | Trimmer Requirements  |                  |                  |                                      |
|                              | Suggested I-Joist     | Alternative IJC  |                  | Header to Trimmer Hanger Requirement |
|                              |                       | LVL              | Glulam Beam      |                                      |
| 14                           |                       | 3-1/2" x 9-1/2"  | 3-1/2" x 9-1/2"  | Type A                               |
| 16                           | Use Alternative IJC   |                  |                  |                                      |
| 18                           |                       | 5-1/4" x 9-1/2"  | 5-1/2" x 9-1/2"  |                                      |
| 20                           |                       |                  | 3-1/2" x 11-7/8" |                                      |
| 22                           |                       | 3-1/2" x 11-7/8" | 5-1/2" x 11-7/8" |                                      |

**Notes:**

- Header length not to exceed 12 ft.
- Type A face- or top-mounted hanger – 1450 lbf.
- Minimum grade LVL based on  $E = 2,000,000$  psi,  $F_b = 2,900$  psi, and  $F_v = 285$  psi
- Minimum grade glulam beam based on  $E = 1,800,000$  psi,  $F_b = 2,400$  psi, and  $F_v = 270$  psi

We have field representatives in most major U.S. cities and in Canada who can help answer questions involving APA and APA EWS trademarked products. For additional assistance in specifying engineered wood products or systems, contact us:

**APA – THE ENGINEERED WOOD ASSOCIATION HEADQUARTERS**

7011 So. 19th St. ■ P.O. Box 11700  
Tacoma, Washington 98411-0700  
(253) 565-6600 ■ Fax: (253) 565-7265

Web Address:



[www.apawood.org](http://www.apawood.org)

**PRODUCT SUPPORT HELP DESK**

(253) 620-7400

E-mail Address: [help@apawood.org](mailto:help@apawood.org)

(Offices: Bournemouth, United Kingdom; Mexico City, Mexico; Tokyo, Japan.)

*The product use recommendations in this publication are based on the continuing programs of laboratory testing, product research, and comprehensive field experience of Engineered Wood Systems. However, because EWS has no control over quality of workmanship or the conditions under which engineered wood products are used, it cannot accept responsibility for product performance or designs as actually constructed. Because engineered wood product performance requirements vary geographically, consult your local architect, engineer or design professional to assure compliance with code, construction, and performance requirements.*

Form No. EWS B710  
Issued January 2002/0010

